



Wednesday, 31 October 2012

## LICENSING SUB-COMMITTEE

A meeting of **Licensing Sub-Committee** will be held on

**Thursday, 8 November 2012**

commencing at **9.30 am**

The meeting will be held in the Meadfoot Room, Town Hall, Castle Circus,  
Torquay, TQ1 3DR

### Members of the Committee

Councillor Addis  
Councillor Faulkner (A)

Councillor Hytche

---

**Working for a healthy, prosperous and happy Bay**

---

For information relating to this meeting or to request a copy in another format or language please contact:

**Kay Heywood, Town Hall, Castle Circus, Torquay, TQ1 3DR**  
**01803 207026**

Email: [governance.support@torbay.gov.uk](mailto:governance.support@torbay.gov.uk)



# LICENSING SUB-COMMITTEE AGENDA

1. **Election of Chairman/woman**  
To elect a Chairman/woman for the meeting.
2. **Apologies**  
To receive apologies for absence, including notifications of any changes to the membership of the Committee.
3. **Minutes** (Pages 1 - 5)  
To confirm as a correct record the Minutes of the meeting of a Sub-Committee held on 18 October 2012.
4. **Declarations of interests**
  - (a) To receive declarations of non pecuniary interests in respect of items on this agenda  
**For reference:** Having declared their non pecuniary interest members may remain in the meeting and speak and, vote on the matter in question. A completed disclosure of interests form should be returned to the Clerk before the conclusion of the meeting.
  - (b) To receive declarations of disclosable pecuniary interests in respect of items on this agenda  
**For reference:** Where a Member has a disclosable pecuniary interest he/she must leave the meeting during consideration of the item. However, the Member may remain in the meeting to make representations, answer questions or give evidence if the public have a right to do so, but having done so the Member must then immediately leave the meeting, may not vote and must not improperly seek to influence the outcome of the matter. A completed disclosure of interests form should be returned to the Clerk before the conclusion of the meeting.  
  
(**Please Note:** If Members and Officers wish to seek advice on any potential interests they may have, they should contact Governance Support or Legal Services prior to the meeting.)
5. **Urgent items**  
To consider any other items that the Chairman decides are urgent.
6. **Licensing Act 2003 – An application for a Variation to a Premises Licence in respect of Bed Bar, 26 Victoria Parade, Torquay TQ1 2BD** (Pages 6 - 47)  
To consider an application for a Variation to a Premises Licence in respect of Bed Bar, 26 Victoria Parade, Torquay TQ1 2BD.



## Minutes of the Licensing Sub-Committee

18 October 2012

-: Present :-

Councillors Addis, Stocks and Bent (In place of Brooksbank)

---

### 17. Election of Chairman/woman

Councillor Addis was elected as Chairman for the meeting.

### 18. Apologies

It was reported that the membership of the Sub-Committee had been amended for this meeting by including Councillor Bent instead of Councillor Brooksbank.

### 19. Minutes

The Minutes of the meetings of the Sub-Committee held on 16 August 2012, 23 August 2012 and 20 September 2012 were confirmed as a correct record and signed by the Chairman.

### 20. Licensing Act 2003 – An application for a Premises Licence – Minerva Hotel, 3 Adelphi Road, Paignton TQ4 6AW

Members were informed that the Applicant had not returned their Notice and was not in attendance. However, the Owner and the General Manager of the Minerva Hotel were present.

Following enquiries with Officers of the Licensing Department which resulted in confirmation that they have no record of dealing with these individuals in the course of this application, the Legal Officer advised that this matter should not proceed in the absence of or written indication from the Applicant that those present be permitted to act on his behalf.

Following discussions, it was agreed to put the matter back until 11.15am for either the named Applicant to attend or written and signed permission by the Applicant for the Owner and/or General Manager to present the application on his behalf. The Owner of the Premises was advised by the Legal Officer that if neither of these proposals could be obtained, then the matter would be rescheduled to the next available Licensing Sub- Committee which would be on the 8<sup>th</sup> November 2012.

Following the arrival of the Applicant, Members considered a report on an application for a Premises Licence in respect of Minerva Hotel, 3 Adelphi Road, Paignton TQ4 6AW.

Written Representations received from:

Name	Details	Date of Representation
Public Protection	Representation received in respect of the Licensing Objective 'The Prevention of Public Nuisance'.	20 September 2012
Members of the Public	Seven Representations received in respect of the Licensing Objectives 'The Prevention of Public Nuisance' and 'The Prevention of Crime and Disorder'.	19 September 2012 (2) 24 September 2012 (2) 25 September 2012 26 September 2012

The Licensing Sub-Committee noted that some Notices had not been returned by Members of the Public who knew the Meeting was taking place. Members agreed it was in the public interest to continue with the meeting.

A plan was circulated to Members with the Chairman's approval, which had been omitted from the submitted report at Appendix 2 – Plan of Premises along with a Google Map of the premises location for Members information.

Oral Representations received from:

Name	Details
The Applicant and General Manager	The Applicant outlined his application, as set out in the submitted documents and responded to Members questions.
Public Protection	The Public Protection Officer outlined details of his submitted document and responded to Members questions.
Local Ward Councillor	The Local Ward Councillor highlighted her concerns in respect of the application and responded to Members questions.

Applicant's response to Representations

The Steak House is to be a fine dining family restaurant for up to 30 patrons and residents of the Hotel and would not be open to members of the public who only wanted a drink

Decision

That the application for a Premises Licence in respect of Minerva Hotel, 3 Adelphi Road, Paignton TQ4 6AW be granted from 6pm to 11pm Monday to Saturday and 6pm to 10pm Sunday, subject to the following conditions which are in addition to those proposed by the Applicant in their Operating Schedule:

- 1) Service of alcohol shall be by Waiter/Waitress service only and patrons shall be seated;
- 2) Alcohol may only be purchased for consumption on the premises when ordering a table meal;
- 3) No drinks shall be taken or consumed in the outside area of the premises;
- 4) No more than 6 people shall be permitted to smoke in the designated smoking area after 9pm;
- 5) The designated smoking area shall be monitored by staff to ensure that patrons do not unreasonably disturb nearby residents;
- 6) No bottles to be emptied into bins which are situated outside between the hours of 8pm and 8am;
- 7) Patrons of the premises shall be reminded by staff to leave in a quiet and orderly manner so as not to unreasonably disturb nearby residents.

Reason for Decision

Having carefully considered all the oral and written Representations, Members resolved to grant the Licence subject to the conditions outlined in their decision.

In doing so, Members were satisfied that these conditions would seek to address the concerns raised in the Representations put forward by both the Interested Parties and the Responsible Authority. In addition, Members had regard to the Council's Licensing Statement of Principles 2011 Policy and saw no reason to depart from its recommendation which sought to restrict licensable activities taking place within premises that are in close proximity to residential properties after 11pm.

**21. Licensing Act 2003 – An application for a Variation to a Premises Licence in respect of Waters Edge Hotel, Corbyn Head, Torbay Road, Torquay TQ2 6QH**

Members considered a report on an application for a Variation to a Premises Licence in respect of Waters Edge Hotel, Corbyn Head, Torbay Road, Torquay TQ2 6QH.

Written Representation received from:

Name	Details	Date of Representation
Member of the Public	One Representation received in respect of the Licensing Objective 'The Prevention of Public Nuisance'.	12 September 2012
Applicants Solicitor	Applicant's Solicitor submitted correspondence to the Council's Licensing Department which addressed concerns raised by the Interested Party in their written Representation.	15 October 2012

The Licensing Sub-Committee noted that the Interested Party had returned their Notice to confirm that they would not be attending the hearing. The Council's Senior Licensing Officer presenting the matter informed Members that she had spoken with Interested Party at length and they felt it was not necessary to attend the hearing, as all the points were covered in their submitted Representation. In light of these facts, Members agreed it was in the public interest to continue with the hearing in the absence of the Interested Party.

Members noted that there were no Representations from any of the Responsible Authorities.

Oral Representations received from:

Name	Details
The Applicant's Solicitor	The Applicant's Solicitor outlined the application, as set out in the submitted documents and responded to Members questions.

Decision

That the application for a Variation to a Premises Licence in respect of Waters Edge Hotel, Corbyn Head, Torbay Road, Torquay TQ2 6QH be granted as applied for, subject to the conditions put forward by the Applicant in their Operating Schedule and that the proposed removal of conditions, 3, 4 and 6 at Annexe 2 of the Premises Licence 277, be removed.

Reason for Decision

Having carefully considered the oral and written Representations, Members resolved to grant the application having been satisfied that the conditions put forward by the Applicant have addressed the previous nuisance, as experienced by the Interested Party which has since resulted in no further complaints. This position was confirmed by the Council's Environmental Protection Officer who was present at the hearing.

Chairman

---

# Agenda Item 6



Briefing Report  
No:

Public Agenda Item: **Yes**

Title: Licensing Act 2003 – An application for a Variation to a Premises Licence in respect of Bed Bar, 26 Victoria Parade, Torquay TQ1 2BD

Wards Affected: **Tormohun**

To: **Licensing Sub-Committee**

On: **8<sup>th</sup> November 2012**

Contact Officer: **Mandy Guy**  
Telephone: **01803 208124**  
E.mail: **Licensing@torbay.gov.uk**

---

## 1. Key points and Summary

- 1.1 To consider and determine an application, in respect of the Premise detailed above, for a Variation to a Premises Licence.
- 1.2 The application relates to all the Corporate Priorities within the Community Plan.
- 1.3 The matters raised relate to the Licensing Objective “The Prevention of Public Nuisance”.
- 1.4 The matter must be considered on its own merits having received details of the issues arising either at a hearing or by written Representations if all parties have agreed that a hearing is not necessary. Having regard to the Representations and issues arising, a decision must be made to take such steps as are necessary for the promotion of the licensing objectives. These are either:-
  - (a) to modify the conditions of the licence, or
  - (b) reject the application in whole or in part.

For this purpose, the conditions of the licence are modified if any of them is altered or omitted or any new condition is added.

- 1.5 Reasons for the decision must be given for inclusion in the appropriate Notices required to be served on the Interested Parties and Responsible Authorities at the determination of the matter.



## **2. Introduction**

- 2.1 An application has been made under Section 34 of the Act for a Variation to a Premises Licence. Details of the application are shown in Appendix 1. Only the relevant pages of the application are shown.

A brief description of the proposed Variation is as follows:-

Alterations to the plan to remove the small bar in the middle of the Premises and introduce more fixed seating areas via a new stud wall. This is shown on the new plans that have accompanied the application.

To remove the Provision of Boxing and Wrestling Entertainment from the Licence.

To remove the Provision of Indoor Sporting Events from the Licence.

To reduce the following:

The Hours of Regulated Entertainment and the Sale of Alcohol Thursday to Sunday 12.00 to 03.00. (This is a reduction on an hour as the present Licence allows these activities until 04.00).

Late Night Refreshment Thursday to Sunday from 23.00 to 03.00. (This is a reduction on an hour as the present Licence allows this activity until 04.00).

Opening Times Thursday to Sunday 12.00 to 03.30. (This is a reduction on an hour as the present Licence allows them to close at 04.00).

Hours the terraced area may be used for the consumption of alcohol Monday to Sunday 12.00 to 22.00. (There is currently no time limit to the use of this area whilst the premises are open).

- 2.2 The current Premises Licence is shown as Appendix 2.

- 2.3 Torbay Council as the Licensing Authority is satisfied that the Applicant has met the administrative requirements of Section 35(1) but is unable to issue the variation to the Premises Licence, as a relevant Representation has been received from Interested Parties. The Licensing Authority is also satisfied that the Representation was received within the appropriate time-scale, has not been subsequently withdrawn and is not vexatious or frivolous.

We have received one Representation with 2 signatures, from Interested Parties in relation to the Licensing Objective "The Prevention of Public Nuisance". This is shown as Appendix 3.

There have been no other Representations received from any Responsible Authority or any other Interested Party.

- 2.4 The Authority is required to conduct a hearing by the provisions of Section 35(3) unless all parties agree that this is not necessary.

- 2.5 Appropriate Notices have been issued to all parties, as required by the Licensing Act 2003 (Hearing Regulations) 2005, including, where appropriate, details of the Representations and the procedure to be followed at the hearing.

- 2.6 If the application is refused, in whole or in part, a Right of Appeal to the Magistrates' Court is granted by Section 181 of the Act and, by Paragraph 1 of Schedule 5, to the Applicant.
- 2.7 If the application is granted, a Right of Appeal to the Magistrates' Court is granted by Section 181 of the Act and, by Paragraph 4(2) of Schedule 5 to :-
- (a) The applicant for the variation of the licence against any decision to modify the conditions
  - (b) Any person who made a relevant representation in relation to the application who desires to contend
    - (i) that any variation made ought not to have been made, or
    - (ii) that, when varying the licence, the Licensing Authority ought to have modified the conditions of the licence or ought to have modified them in a different way.
- 2.8 Following such Appeal, the Magistrates' Court may:-
- (a) dismiss the appeal,
  - (b) substitute for the decision appealed against any other decision which could have been made by the Licensing Authority, or
  - (c) remit the case to the Licensing Authority to dispose of it in accordance with the direction of the Court,
- and may make such order as to costs as it thinks fit.

**Frances Hughes**  
**Executive Head Community Safety**

### **Appendices**

Appendix 1	Relevant sections of the application form.
Appendix 2	Copy of the current Premises Licence.
Appendix 3	Representation from Interested Parties.

If the above appendices are not attached to this report, they can be viewed at Connections Offices in Torquay, Paignton and Brixham and Torquay, Paignton, Churston and Brixham Libraries. Copies can also be obtained from the Democratic Services Office, Town Hall, Torquay.

### **Documents available in members' rooms**

None

### **Background Papers:**

The following documents/files were used to compile this report:

The current Premises Licence for the above Premise.  
Torbay Council Licensing Policy 2011.

FORM L



**Application to vary a Premises Licence under the Licensing Act 2003**

**PLEASE READ THE FOLLOWING INSTRUCTIONS FIRST**

Before completing this form please read the guidance notes at the end of the form.  
 If you are completing this form by hand please write legibly in block capitals. In all cases ensure that your answers are inside the boxes and written in black ink. Use additional sheets if necessary.  
 You may wish to keep a copy of the completed form for your records.

I/We UK Club Torquay Ltd

*(Insert name(s) of applicant)*

being the premises licence holder, apply to vary a premises licence under section 34 of the Licensing Act 2003 for the premises described in Part 1 below

<b>Premises licence number</b> 865
---------------------------------------

**Part 1 – Premises Details**

<b>Postal address of premises or, if none, ordnance survey map reference or description</b> 26 Victoria Parade			
<b>Post town</b>	Torquay	<b>Post code</b>	TQ1 2BD

Telephone number at premises (if any)	
Non-domestic rateable value of premises	£55000

**Part 2 – Applicant details**

**Part 3 - Variation**

Please tick yes

Do you want the proposed variation to have effect as soon as possible?

If not do you want the variation to take effect from

Day		Month		Year	

**Please describe briefly the nature of the proposed variation (Please see guidance note 1)**

Remove the small bar in the middle of the venue & introduce more fixed seating areas via a new stud wall as per the plans submitted. Remove the provision for boxing and wrestling entertainment from the licence. Remove the provision for indoor sporting events from the licence.

Reduce the following:

The hours for regulated entertainment and the sale of alcohol :

Thursday to Sunday 12:00 to 03:00

Late night refreshment

Thursday to Sunday 23:00 to 03:00

Opening times

Thursday to Sunday 10:00 to 03:30

Hours the terraced area may be used for the consumption of alcohol

Monday to Sunday 12:00 to 22:00

If your proposed variation would mean that 5,000 or more people are expected to attend the premises at any one time, please state the number expected to attend

## Part 4 Operating Schedule

Please complete those parts of the Operating Schedule below which would be subject to change if this application to vary is successful.

### Provision of regulated entertainment

Please tick yes

- |  |                                     |
|--|-------------------------------------|
| a) plays (if ticking yes, fill in box A)   | <input checked="" type="checkbox"/> |
| b) films (if ticking yes, fill in box B)   | <input checked="" type="checkbox"/> |
| c) indoor sporting events (if ticking yes, fill in box C)  | <input type="checkbox"/>            |
| d) boxing or wrestling entertainment (if ticking yes, fill in box D)   | <input type="checkbox"/>            |
| e) live music (if ticking yes, fill in box E)  | <input checked="" type="checkbox"/> |
| f) recorded music (if ticking yes, fill in box F)  | <input checked="" type="checkbox"/> |
| g) performances of dance (if ticking yes, fill in box G)   | <input checked="" type="checkbox"/> |
| h) anything of a similar description to that falling within (e), (f) or (g)<br>(if ticking yes, fill in box H) | <input checked="" type="checkbox"/> |

### Provision of entertainment facilities:

- |  |                                     |
|--|-------------------------------------|
| i) making music (if ticking yes, fill in box I)  | <input checked="" type="checkbox"/> |
| j) dancing (if ticking yes, fill in box J)   | <input checked="" type="checkbox"/> |
| k) entertainment of a similar description to that falling within (i) or (j)<br>(if ticking yes, fill in box K) | <input checked="" type="checkbox"/> |

### Provision of late night refreshment (if ticking yes, fill in box L)

### Sale by retail of alcohol (if ticking yes, fill in box M)

In all cases complete boxes N, O and P

**A**

<b>Plays</b> Standard days and timings (please read guidance note 6)			<b><u>Will the performance of a play take place indoors or outdoors or both – please tick</u></b> (please read guidance note 2)	Indoors	<input checked="" type="checkbox"/>
				Outdoors	<input type="checkbox"/>
				Both	<input type="checkbox"/>
<b>Day</b>	<b>Start</b>	<b>Finish</b>	<b><u>Please give further details here</u></b> (please read guidance note 3)		
Mon	10.00	02.00			
Tue	10.00	02.00			
Wed	10.00	02.30	<b><u>State any seasonal variations for performing plays</u></b> (please read guidance note 4) On the morning British Summer Time (BST) commences the licensable activity will be extended by an additional hour New Years Eve from the end of permitted hours until the start of permitted hours on New Years Day		
Thur	10.00	03.00			
Fri	10.00	03.00	<b><u>Non standard timings. Where you intend to use the premises for the performance of plays at different times to those listed in the column on the left, please list</u></b> (please read guidance note 5)		
Sat	10.00	03.00			
Sun	10.00	03.00			

**B**

<b>Films</b> Standard days and timings (please read guidance note 6)			<b>Will the exhibition of films take place indoors or outdoors or both – please tick</b> (please read guidance note 2)	Indoors	<input checked="" type="checkbox"/>
				Outdoors	<input type="checkbox"/>
				Both	<input type="checkbox"/>
<b>Day</b>	<b>Start</b>	<b>Finish</b>	<b>Please give further details here</b> (please read guidance note 3)		
Mon	10.00	02.00			
			<b>State any seasonal variations for the exhibition of films</b> (please read guidance note 4) On the morning British Summer Time (BST) commences the licensable activity will be extended by an additional hour New Years Eve from the end of permitted hours until the start of permitted hours on New Years Day		
Tue	10.00	02.00			
			<b>Non standard timings. Where you intend to use the premises for the exhibition of films at different times to those listed in the column on the left, please list</b> (please read guidance note 5)		
Wed	10.00	02.30			
Thur	10.00	03.00			
Fri	10.00	03.00			
Sat	10.00	03.00			
Sun	10.00	03.00			

**E**

<b>Live music</b> Standard days and timings (please read guidance note 6)			<b>Will the performance of live music take place indoors or outdoors or both – please tick</b> (please read guidance note 2)	Indoors	<input checked="" type="checkbox"/>
				Outdoors	<input type="checkbox"/>
				Both	<input type="checkbox"/>
<b>Day</b>	<b>Start</b>	<b>Finish</b>	<b>Please give further details here</b> (please read guidance note 3)		
Mon	10.00	02.00			
			<b>State any seasonal variations for the performance of live music</b> (please read guidance note 4) On the morning British Summer Time (BST) commences the licensable activity will be extended by an additional hour New Years Eve from the end of permitted hours until the start of permitted hours on New Years Day		
Tue	10.00	02.00			
			<b>Non standard timings. Where you intend to use the premises for the performance of live music at different times to those listed in the column on the left, please list</b> (please read guidance note 5)		
Wed	10.00	02.30			
Thur	10.00	03.00			
Fri	10.00	03.00			
Sat	10.00	03.00			
Sun	10.00	03.00			



**F**

Recorded music Standard days and timings (please read guidance note 6)			Will the playing of recorded music take place <u>indoors or outdoors or both – please tick</u> (please read guidance note 2)	Indoors	<input checked="" type="checkbox"/>
				Outdoors	<input type="checkbox"/>
				Both	<input type="checkbox"/>
Day	Start	Finish			
Mon	10.00	02.00	<b>Please give further details here</b> (please read guidance note 3)		
Tue	10.00	02.00			
Wed	10.00	02.30	<b>State any seasonal variations for the playing of recorded music</b> (please read guidance note 4) On the morning British Summer Time (BST) commences the licensable activity will be extended by an additional hour New Years Eve from the end of permitted hours until the start of permitted hours on New Years Day		
Thur	10.00	03.00			
Fri	10.00	03.00	<b>Non standard timings. Where you intend to use the premises for the playing of recorded music at different times to those listed in the column on the left, please list</b> (please read guidance note 5)		
Sat	10.00	03.00			
Sun	10.00	03.00			

**G**

<b>Performances of dance</b> Standard days and timings (please read guidance note 6)			<b>Will the performance of dance take place indoors or outdoors or both – please tick</b> (please read guidance note 2)	Indoors	<input checked="" type="checkbox"/>
				Outdoors	<input type="checkbox"/>
				Both	<input type="checkbox"/>
<b>Day</b>	<b>Start</b>	<b>Finish</b>	<b>Please give further details here</b> (please read guidance note 3)		
Mon	10.00	02.00			
Tue	10.00	02.00			
Wed	10.00	02.30	<b>State any seasonal variations for the performance of dance</b> (please read guidance note 4) On the morning British Summer Time (BST) commences the licensable activity will be extended by an additional hour New Years Eve from the end of permitted hours until the start of permitted hours on New Years Day		
Thur	10.00	03.00			
Fri	10.00	03.00	<b>Non standard timings. Where you intend to use the premises for the performance of dance at different times to those listed in the column on the left, please list</b> (please read guidance note 5)		
Sat	10.00	03.00			
Sun	10.00	03.00			

**H**

<b>Anything of a similar description to that falling within (e), (f) or (g)</b> Standard days and timings (please read guidance note 6)			<b><u>Please give a description of the type of entertainment you will be providing</u></b>		
<b>Day</b>	<b>Start</b>	<b>Finish</b>	<b><u>Will this entertainment take place indoors or outdoors or both – please tick</u></b> (please read guidance note 2)	Indoors	<input checked="" type="checkbox"/>
Mon	10.00	02.00		Outdoors	<input type="checkbox"/>
				Both	<input type="checkbox"/>
Tue	10.00	02.00	<b><u>Please give further details here</u></b> (please read guidance note 3)		
Wed	10.00	02.30			
Thur	10.00	03.00	<b><u>State any seasonal variations for entertainment of a similar description to that falling within (e), (f) or (g)</u></b> (please read guidance note 4) On the morning British Summer Time (BST) commences the licensable activity will be extended by an additional hour New Years Eve from the end of permitted hours until the start of permitted hours on New Years Day		
Fri	10.00	03.00			
Sat	10.00	03.00	<b><u>Non standard timings. Where you intend to use the premises for the entertainment of a similar description to that falling within (e), (f) or (g) at different times to those listed in the column on the left, please list</u></b> (please read guidance note 5)		
Sun	10.00	03.00			

1

<b>Provision of facilities for making music</b> Standard days and timings (please read guidance note 6)			<b><u>Please give a description of the facilities for making music you will be providing</u></b>  	
			<b><u>Will the facilities for making music be indoors or outdoors or both – please tick</u></b> (please read guidance note 2)	
			Outdoors <input type="checkbox"/>	
			Both <input type="checkbox"/>	
Day	Start	Finish	<b><u>Please give further details here</u></b> (please read guidance note 3)	
Mon	10.00	02.00		
Tue	10.00	02.00		
Wed	10.00	02.30		
Thur	10.00	03.00		
			<b><u>State any seasonal variations for the provision of facilities for making music</u></b> (please read guidance note 4) On the morning British Summer Time (BST) commences the licensable activity will be extended by an additional hour New Years Eve from the end of permitted hours until the start of permitted hours on New Years Day	
Fri	10.00	03.00	<b><u>Non standard timings. Where you intend to use the premises for provision of facilities for making music at different times to those listed in the column on the left, please list</u></b> (please read guidance note 5)	
Sat	10.00	03.00		
Sun	10.00	03.00		

J

<b>Provision of facilities for dancing</b> Standard days and timings (please read guidance note 6)			<b>Will the facilities for dancing be indoors or outdoors or both – please tick</b> (see guidance note 2)	Indoors <input checked="" type="checkbox"/>
				Outdoors <input type="checkbox"/>
				Both <input type="checkbox"/>
<b>Day</b>	<b>Start</b>	<b>Finish</b>	<b>Please give a description of the facilities for dancing you will be providing</b>	
Mon	10.00	02.00	<b>Please give further details here</b> (please read guidance note 3)	
Tue	10.00	02.00		
Wed	10.00	02.30	<b>State any seasonal variations for providing dancing facilities</b> (please read guidance note 4) On the morning British Summer Time (BST) commences the licensable activity will be extended by an additional hour New Years Eve from the end of permitted hours until the start of permitted hours on New Years Day	
Thur	10.00	03.00		
Fri	10.00	03.00	<b>Non standard timings. Where you intend to use the premises for the provision of facilities for dancing at different times to those listed in the column on the left, please list</b> (please read guidance note 5)	
Sat	10.00	03.00		
Sun	10.00	03.00		

**K**

<b>Provision of facilities for entertainment of a similar description to that falling within i or j Standard days and timings (please read guidance note 6)</b>			<b><u>Please give a description of the type of entertainment facility you will be providing</u></b>	
Day	Start	Finish	<b><u>Will the entertainment facility be indoors or outdoors or both – please tick</u></b> (please read guidance note 2)	Indoors <input checked="" type="checkbox"/>
Mon	10.00	02.00		Outdoors <input type="checkbox"/>
				Both <input type="checkbox"/>
Tue	10.00	02.00	<b><u>Please give further details here</u></b> (please read guidance note 3)	
Wed	10.00	02.30		
Thur	10.00	03.00	<b><u>State any seasonal variations for the provision of facilities for entertainment of a similar description to that falling within i or j</u></b> (please read guidance note 4) On the morning British Summer Time (BST) commences the licensable activity will be extended by an additional hour New Years Eve from the end of permitted hours until the start of permitted hours on New Years Day	
Fri	10.00	03.00		
Sat	10.00	03.00	<b><u>Non standard timings. Where you intend to use the premises for the provision of facilities for entertainment of a similar description to that falling within i or j at different times to those listed in the column on the left, please list</u></b> (please read guidance note 5)	
Sun	10.00	03.00		

L

<b>Late night refreshment</b> Standard days and timings (please read guidance note 6)			<b>Will the provision of late night refreshment take place indoors or outdoors or both – please tick</b> (please read guidance note 2)	Indoors	<input checked="" type="checkbox"/>
				Outdoors	<input type="checkbox"/>
				Both	<input type="checkbox"/>
<b>Day</b>	<b>Start</b>	<b>Finish</b>	<b>Please give further details here</b> (please read guidance note 3)		
Mon	23:00	02.00			
Tue	23:00	02.00			
Wed	23:00	02.30			
			<b>State any seasonal variations for the provision of late night refreshment</b> (please read guidance note 4) On the morning British Summer Time (BST) commences the licensable activity will be extended by an additional hour New Years Eve from the end of permitted hours until the start of permitted hours on New Years Day		
Thur	23:00	03.00			
Fri	23:00	03.00			
			<b>Non standard timings. Where you intend to use the premises for the provision of late night refreshment at different times, to those listed in the column on the left, please list</b> (please read guidance note 5)		
Sat	23:00	03.00			
Sun	23:00	03.00			

**M**

<b>Supply of alcohol</b> Standard days and timings (please read guidance note 6)			<b>Will the supply of alcohol be for consumption (Please tick box) (please read guidance note 7)</b>	On the premises	<input type="checkbox"/>
				Off the premises	<input type="checkbox"/>
				Both	<input checked="" type="checkbox"/>
<b>Day</b>	<b>Start</b>	<b>Finish</b>			
Mon	10.00	02.00	<b>State any seasonal variations for the supply of alcohol</b> (please read guidance note 4) On the morning British Summer Time (BST) commences the licensable activity will be extended by an additional hour New Years Eve from the end of permitted hours until the start of permitted hours on New Years Day		
Tue	10.00	02.00			
Wed	10.00	02.30			
Thur	10.00	03.00	<b>Non-standard timings. Where you intend to use the premises for the supply of alcohol at different times to those listed in the column on the left, please list</b> (please read guidance note 5) Reduce the following: Hours the terraced area may be used for the consumption of alcohol Monday to Sunday 12:00 to 22:00		
Fri	10.00	03.00			
Sat	10.00	03.00			
Sun	10.00	03.00			

**N**

**Please highlight any adult entertainment or services, activities, other entertainment or matters ancillary to the use of the premises that may give rise to concern in respect of children** (please read guidance note 8)

None



O

<b>Hours premises are open to the public</b> Standard days and timings (please read guidance note 6)			<b>State any seasonal variations</b> (please read guidance note 4) On the morning British Summer Time (BST) commences the licensable activity will be extended by an additional hour New Years Eve from the end of permitted hours until the start of permitted hours on New Years Day
Day	Start	Finish	
Mon	10.00	02.30	<b>Non standard timings. Where you intend the premises to be open to the public at different times from those listed in the column on the left, please list</b> (please read guidance note 5)
Tue	10.00	02.30	
Wed	10.00	03.00	
Thur	10.00	03.30	
Fri	10.00	03.30	
Sat	10.00	03.30	
Sun	10.00	03.30	

Please identify those conditions currently imposed on the licence which you believe could be removed as a consequence of the proposed variation you are seeking

**P** Describe any additional steps you intend to take to promote the four licensing objectives as a result of the proposed variation:

**a) General – all four licensing objectives (b,c,d,e) (please read guidance note 9)**

Reduce the following:  
Hours the terraced area may be used for the consumption of alcohol  
Monday to Sunday 12:00 to 22:00.

**b) The prevention of crime and disorder**

**c) Public safety**

**d) The prevention of public nuisance**

**e) The protection of children from harm**

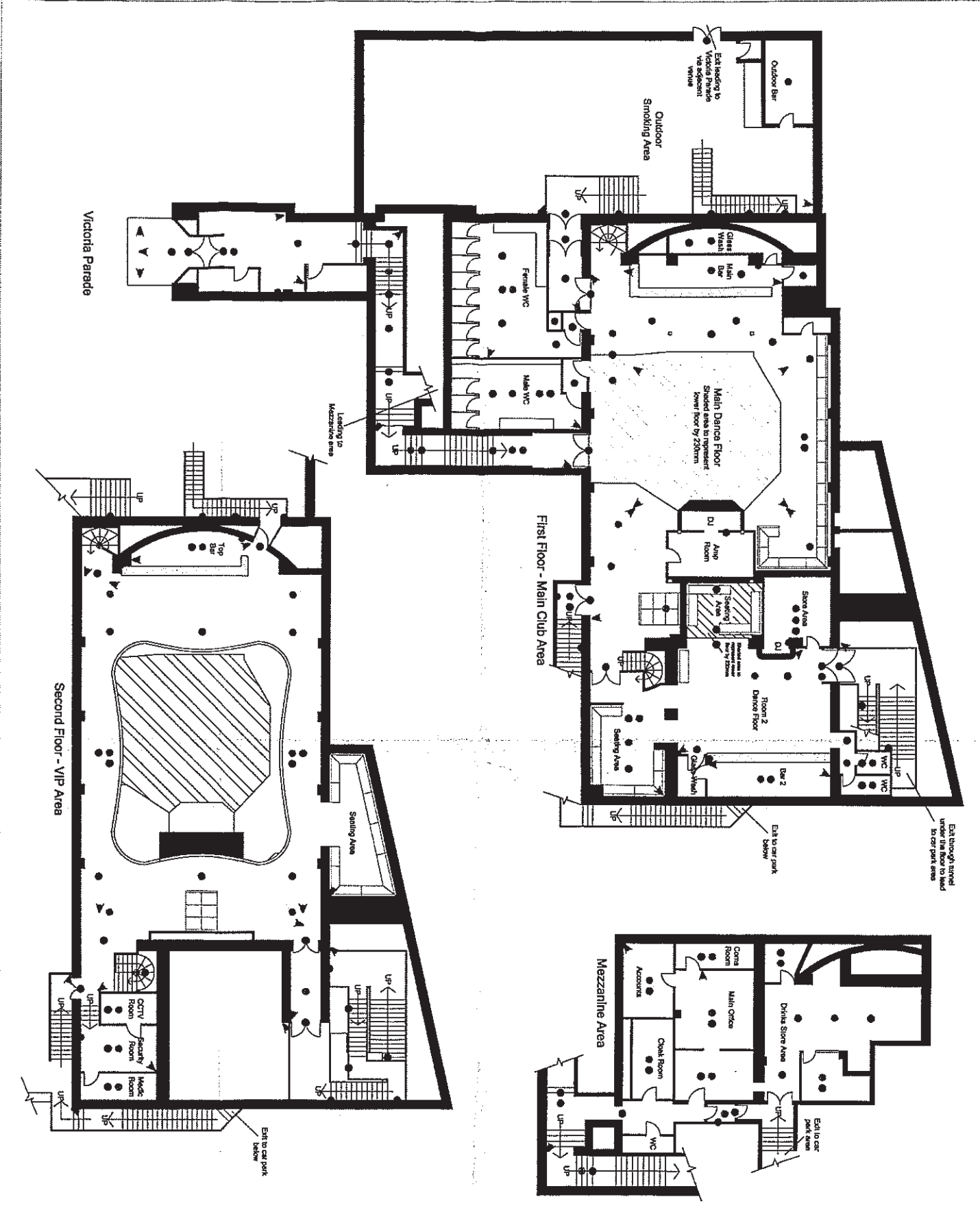

Device Position Key	
●	Fire Detection Sensor
●	Dual Smoke & Heat
●	Fire Alarm Call Point
●	Fire Alarm Public Address Evacuation Speaker
▲	CCTV Camera
●	Day & Night Illumination
●	Emergency Lighting
□	Fixed Seating

<b>Inova Technical Ltd</b> 2 Church Path Woking, Surrey, GU21 6EL 01483 602159	
<b>Project</b>	Licensed Premises Plan Proposed Layout - Bar Bar
<b>Location</b>	Bar Bar, Victoria Parade, Tisbury, TQ1 2BD
<b>Client</b>	Inova 3 Limited
<b>Date</b>	20th August 2012
<b>Drawing</b>	BRTCI
<b>Revision</b>	1/1
<b>Scale</b>	1:100

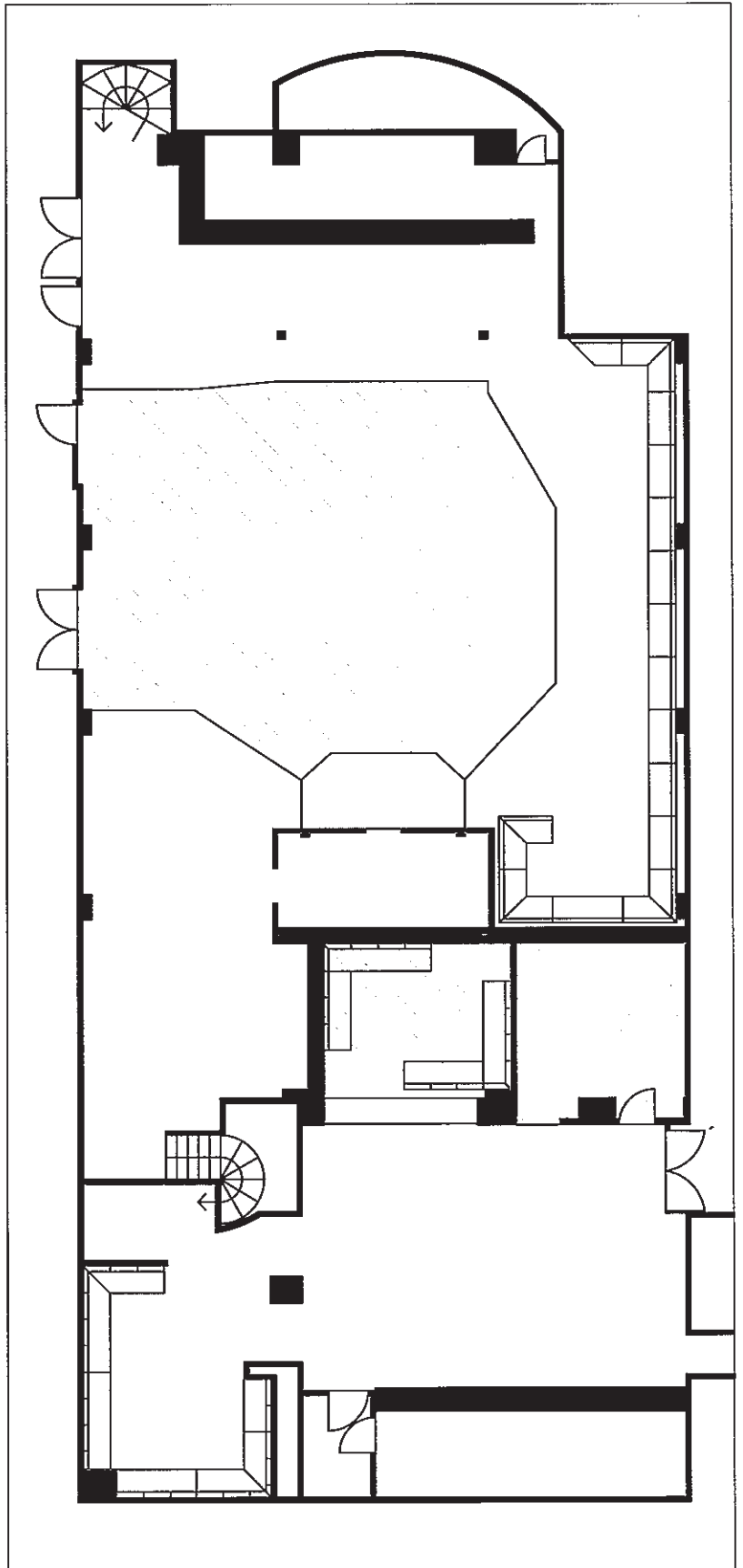

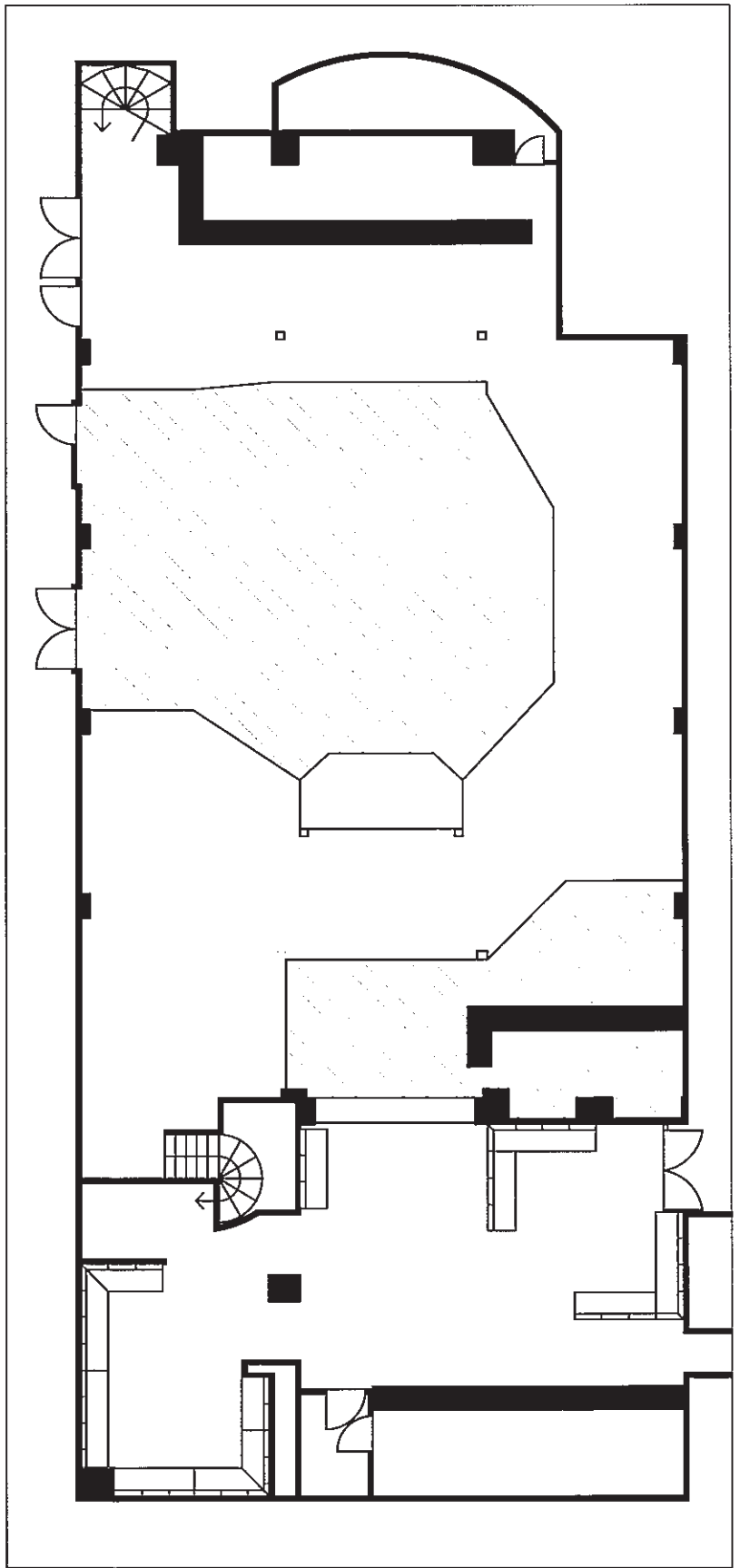

# Agenda Item 6

## Appendix 2

Licensing Act 2003

# Premises Licence

# 865

**LOCAL AUTHORITY**



Licensing Section  
 Torbay Council  
 Roebuck House  
 Abbey Road  
 TORQUAY  
 DEVON  
 TQ2 5EJ

COPY

Part 1 - Premises Details

**POSTAL ADDRESS OF PREMISES, OR IF NONE, ORDNANCE SURVEY MAP REFERENCE OR DESCRIPTION**

**Bed Bar**

26 Victoria Parade, Torquay, Devon, TQ1 2BD.

Telephone 01803 611055

**WHERE THE LICENCE IS TIME LIMITED THE DATES**

Not applicable

**LICENSABLE ACTIVITIES AUTHORISED BY THE LICENCE**

- a performance of a play
- an exhibition of a film
- an indoor sporting event
- a boxing or wrestling entertainment
- a performance of live music
- any playing of recorded music
- a performance of dance
- entertainment of a similar description to that falling within a performance of live music, any playing of recorded music or a performance of dance
- entertainment facilities for making music
- entertainment facilities for dancing
- entertainment of a similar description to that falling within entertainment facilities for making music or dancing
- provision of late night refreshment
- the sale by retail of alcohol

**THE TIMES THE LICENCE AUTHORISES THE CARRYING OUT OF LICENSABLE ACTIVITIES**

Activity (and Area if applicable)	Description	Time From	Time To
A. Performance of a play (Indoors)	Monday to Sunday	10:00am	2:00am
B. Exhibition of films (Indoors)	Monday	10:00am	2:00am
	Tuesday	10:00am	2:00am
	Wednesday	10:00am	2:30am
	Thursday to Saturday	10:00am	4:00am
	Sunday	10:00am	3:00am
C. Indoor sporting event	Monday	10:00am	2:00am
	Tuesday	10:00am	2:00am
	Wednesday	10:00am	2:30am
	Thursday to Saturday	10:00am	4:00am
	Sunday	10:00am	3:00am

## THE TIMES THE LICENCE AUTHORISES THE CARRYING OUT OF LICENSABLE ACTIVITIES continued ...

Activity (and Area if applicable)	Description	Time From	Time To
<b>C. Indoor sporting event continued ...</b>			
<b>D. Boxing or wrestling entertainment (Indoors)</b>			
	Monday	10:00am	2:00am
	Tuesday	10:00am	2:00am
	Wednesday	10:00am	2:30am
	Thursday to Saturday	10:00am	4:00am
	Sunday	10:00am	3:00am
<b>E. Performance of live music (Indoors)</b>			
	Monday	10:00am	2:00am
	Tuesday	10:00am	2:00am
	Wednesday	10:00am	2:30am
	Thursday	10:00am	4:00am
	Friday	10:00am	4:00am
	Saturday	10:00am	4:00am
	Sunday	10:00am	3:00am
On New Year's Eve from the end of permitted hours on New Year's Eve to the start of permitted hours on the following day.			
<b>F. Playing of recorded music (Indoors &amp; Outdoors)</b>			
	Monday	10:00am	2:00am
	Tuesday	10:00am	2:00am
	Wednesday	10:00am	2:30am
	Thursday to Saturday	10:00am	4:00am
	Sunday	10:00am	3:00am
On New Year's Eve from the end of permitted hours on New Year's Eve to the start of permitted hours on the following day.			
<b>G. Performance of dance (Indoors)</b>			
	Monday	10:00am	2:00am
	Tuesday	10:00am	2:00am
	Wednesday	10:00am	2:30am
	Thursday to Saturday	10:00am	4:00am
	Sunday	10:00am	3:00am
On New Year's Eve from the end of permitted hours on New Year's Eve to the start of permitted hours on the following day.			
<b>H. Entertainment of a similar description to that falling within E, F, or G (Indoors)</b>			
	Monday	10:00am	2:00am
	Tuesday	10:00am	2:00am
	Wednesday	10:00am	2:30am
	Thursday	10:00am	4:00am
	Friday	10:00am	4:00am
	Saturday	10:00am	4:00am
	Sunday	10:00am	3:00am
On New Year's Eve from the end of permitted hours on New Year's Eve to the start of permitted hours on the following day.			
<b>I. Provision of facilities for making music (Indoors)</b>			
	Monday	10:00am	2:00am
	Tuesday	10:00am	2:00am
	Wednesday	10:00am	2:30am
	Thursday to Saturday	10:00am	4:00am
	Sunday	10:00am	3:00am
<b>J. Provision of facilities for dancing (Indoors)</b>			
	Monday	10:00am	2:00am
	Tuesday	10:00am	2:00am

**THE TIMES THE LICENCE AUTHORISES THE CARRYING OUT OF LICENSABLE ACTIVITIES continued...**

Activity (and Area if applicable)	Description	Time From	Time To	
J. Provision of facilities for dancing (Indoors) continued ...	Wednesday	10:00am	2:30am	
	Thursday	10:00am	4:00am	
	Friday	10:00am	4:00am	
	Saturday	10:00am	4:00am	
	Sunday	10:00am	3:00am	
	On New Year's Eve from the end of permitted hours on New Year's Eve to the start of permitted hours on the following day.			
K. Provision of facilities for entertainment of a similar description to that falling within I or J (Indoors)	Monday	10:00am	2:00am	
	Tuesday	10:00am	2:00am	
	Wednesday	10:00am	2:30am	
	Thursday to Saturday	10:00am	4:00am	
	Sunday	10:00am	3:00am	
L. Late night refreshment (Indoors & Outdoors)	Monday to Sunday	11:00pm	2:00am	Outdoors only
	Monday	11:00pm	2:00am	Indoors
	Tuesday	11:00pm	2:00am	Indoors
	Wednesday	11:00pm	2:30am	Indoors
	Thursday to Saturday	11:00pm	4:00am	Indoors
	Sunday	11:00pm	3:00am	Indoors
M. The sale by retail of alcohol for consumption ON and OFF the premises	Monday	Noon	2:00am	
	Tuesday	Noon	2:00am	
	Wednesday	Noon	2:30am	
	Thursday to Saturday	Noon	4:00am	
	Sunday	Noon	3:00am	
	On New Year's Eve from the end of permitted hours on New Year's Eve to the start of permitted hours on the following day.			
	Monday to Sunday	Noon	2:00am	Terraced area only

**THE OPENING HOURS OF THE PREMISES**

Description	Time From	Time To
Monday	10:00am	2:30am
Tuesday	10:00am	2:30am
Wednesday	10:00am	3:00am
Thursday to Saturday	10:00am	4:30am
Sunday	10:00am	3:30am
On New Year's Eve from the end of permitted hours on New Year's Eve to the start of permitted hours on the following day.		

**WHERE THE LICENCE AUTHORISES SUPPLIES OF ALCOHOL WHETHER THESE ARE ON AND / OR OFF SUPPLIES**

- M. The sale by retail of alcohol for consumption ON and OFF the premises

## Part 2

**NAME, (REGISTERED) ADDRESS, TELEPHONE NUMBER AND EMAIL (WHERE RELEVANT) OF HOLDER OF PREMISES LICENCE**

Inova 3 Ltd

2 Church Path, Woking, Hampshire, GU21 6EJ.



Licensing Act 2003  
**Premises Licence**

**865**

REGISTERED NUMBER OF HOLDER, FOR EXAMPLE COMPANY NUMBER, CHARITY NUMBER (WHERE APPLICABLE)

NAME, ADDRESS AND TELEPHONE NUMBER OF DESIGNATED PREMISES SUPERVISOR WHERE THE PREMISES LICENCE AUTHORISES THE SUPPLY OF ALCOHOL

Gerard Francis GUTHRIE

PERSONAL LICENCE NUMBER AND ISSUING AUTHORITY OF PERSONAL LICENCE HELD BY DESIGNATED PREMISES SUPERVISOR WHERE THE PREMISES LICENCE AUTHORISES FOR THE SUPPLY OF ALCOHOL

Licence No. LP7000753

Issued by Reading



Steve Cox  
Environmental Health Manager (Commercial)  
22 August 2012

**ANNEXES****ANNEXE 1****MANDATORY CONDITION: WHERE LICENCE AUTHORISES SUPPLY OF ALCOHOL**

- 1) No supply of alcohol may be made under the premises licence:-
- (a) at a time where there is no designated premises supervisor in respect of the premises licence, or
  - (b) at a time when the designated premises supervisor does not hold a personal licence or his/her personal licence is suspended.
- 2) Every supply of alcohol under the premises licence must be made or authorised by a person who holds a personal licence.
- 3) (1) The responsible person shall take all reasonable steps to ensure that staff on relevant premises do not carry out, arrange or participate in any irresponsible promotions in relation to the premises.
- (2) In this paragraph, an irresponsible promotion means any one or more of the following activities, or substantially similar activities, carried on for the purpose of encouraging the sale or supply of alcohol for consumption on the premises in a manner which carries a significant risk of leading or contributing to crime and disorder, prejudice to public safety, public nuisance, or harm to children -
- (a) games or other activities which require or encourage, or are designed to require or encourage, individuals to -
    - (i) drink a quantity of alcohol within a time limit (other than to drink alcohol sold or supplied on the premises before the cessation of the period in which the responsible person is authorised to sell or supply alcohol), or
    - (ii) drink as much alcohol as possible (whether within a time limit or otherwise);
  - (b) provision of unlimited or unspecified quantities of alcohol free or for a fixed or discounted fee to the public or to a group defined by a particular characteristic (other than any promotion or discount available to an individual in respect of alcohol for consumption at a table meal, as defined in section 159 of the Act);
  - (c) provision of free or discounted alcohol or any other thing as a prize to encourage or reward the purchase and consumption of alcohol over a period of 24 hours or less;
  - (d) provision of free or discounted alcohol in relation to the viewing on the premises of a sporting event, where that provision is dependent on -
    - (i) the outcome of a race, competition or other event or process, or
    - (ii) the likelihood of anything occurring or not occurring;
  - (e) selling or supplying alcohol in association with promotional posters or flyers on, or in the vicinity of, the premises which can reasonably be considered to condone, encourage or glamorise anti social behaviour or to refer to the effects of drunkenness in any favourable manner.
- 4) The responsible person shall ensure that no alcohol is dispensed directly by one person into the mouth of another (other than where that other person is unable to drink without assistance by reason of a disability).
- 5) The responsible person shall ensure that free tap water is provided on request to customers where it is reasonably available.
- 6) (1) The premises licence holder or club premises certificate holder shall ensure that an age verification policy applies to the premises in relation to the sale or supply of alcohol.
- (2) The policy must require individuals who appear to the responsible person to be under 18 years of age (or such older age as may be specified in the policy) to produce on request, before being served alcohol, identification bearing their photograph, date of birth and a holographic mark.
- 7). The responsible person shall ensure that -

**ANNEXES continued...**

(a) where any of the following alcoholic drinks is sold or supplied for consumption on the premises (other than alcoholic drinks sold or supplied having been made up in advance ready for sale or supply in a securely closed container) it is available to customers in the following measures -

- (i) beer or cider: ½ pint;
- (ii) gin, rum, vodka or whisky: 25 ml or 35 ml; and
- (iii) still wine in a glass: 125 ml; and

(b) customers are made aware of the availability of these measures.

**MANDATORY CONDITION: EXHIBITION OF FILMS**

- 1) Where the film classification body is specified in the licence, admission of children must be restricted in accordance with any recommendation made by that body.
- 2) Where -
  - (a) the film classification body is not specified in the licence, or
  - (b) the relevant licensing authority has notified the holder of the licence that this condition applies to the film in question,

admission of children must be restricted in accordance with any recommendation made by that licensing authority.

In the case of the aforementioned conditions

“children” means persons aged under 18; and

“film classification body” means the person or persons designated as the authority under section 4 of the Video Recordings Act 1984 (authority to determine suitability of video works for classification).

**MANDATORY CONDITION: DOOR SUPERVISION**

- 1) Where one or more individuals are carrying out security activities, each individual must be licensed by the Security Industry Authority.
- 2) But nothing in the aforementioned conditions requires such a condition to be imposed in respect of a) and b) and (b)(i) and (b)(ii)
  - (a) in respect of premises within paragraph 8(3)(a) of Schedule 2 to the Private Security Industry Act 2001 (c. 12) (premises with premises licences authorising plays or films), are exempt.
  - (b) In respect of premises in relation to-
    - (i) any occasion mentioned in paragraph 8(3)(b) or (c) of that Schedule (premises being used exclusively by club with club premises certificate, under a temporary event notice authorising plays or films or under a gaming licence), or
    - (ii) any occasion within paragraph 8(3)(d) of that Schedule (occasions prescribed by regulations under that Act).
- 3) For the purposes of the aforementioned conditions:-
  - (a) “security activity” means an activity to which paragraph 2(1)(a) of that Schedule applies, and
  - (b) paragraph 8(5) of that Schedule (interpretation of references to an occasion) applies as it applies in relation to paragraph 8 of that Schedule.

**ANNEXE 2**

**CONDITIONS CONSISTENT WITH THE OPERATING SCHEDULE**

**ANNEXES continued ...**

**General**

1. One SIA registered door steward shall be on duty on or around the terrace at all times when the terraced area is open.
2. There shall be no access to the terraced area other than through the premises.
3. The terraced area shall be cleared of all drinks no later than 02.30 hours.
4. Any person employed at the premises in the sale and supply of alcohol, shall attend and successfully complete the BIIAB Level 1 Award in Responsible Alcohol Retailing within 2 months of commencing employment.
5. Notices regarding the sale of alcohol to persons who appear drunk, shall be prominently displayed at all points of sale and supply of alcohol, for the attention of persons so employed.
6. Notices regarding the sale of alcohol to persons who appear drunk, shall be prominently displayed on the premises and at the entrance to the premises, for the attention of all customers.
7. At least 14 days notice shall be given to the Licensing Authority of any Indoor Sporting Events or Boxing or Wrestling Entertainment events.

**The Prevention of Crime and Disorder**

1. A CCTV system of an evidential standard must be installed to the satisfaction of the police and the system in operation at all times the premises are open. All recordings from that system must be kept for a period of 28 days and the Police to have access to recordings at any reasonable time.
2. On every occasion that the premises sells alcohol after midnight and remains open beyond 00.30 hours, SIA door staff must be employed from 22.00 hours until closing time and the ratio of stewards to customers shall be 1 steward for each 100 people, based on occupancy.
3. On every operational day when door supervision is required then those SIA door stewards employed in front of house duties shall wear high visibility reflective jackets for the entirety of their duty.
4. All drinks must be served in toughened glasses, strengthened glasses, plastic receptacles or cans and no alcohol is to be served in glass bottles from which it is intended or likely that a person shall drink.
5. The Premises shall participate in the Nitenet radio communication scheme. The Nitenet Radio will be monitored by either the Premises' Control Room, Head Doorman or Duty Manager whenever the Premises are open to the public.
6. Representatives of Premises Management shall attend at least 2 meetings per calendar year of the Torquay Night-time Economy Forum.
7. There shall be no entry or re-entry for the premises after 02.00 hours.
8. No persons under the age of 18 shall be employed on the premises in connection with the sale of supply of alcohol.
9. There shall be no "all-inclusive-all-you-can-drink" drinks promotions, however, on such occasions when the Premises are being used exclusively for a pre-booked private event a pre-paid bar may be provided. Where any drinks promotions are provided, such promotions must be managed in a responsible manner.
10. There shall be adequate lighting in the reception area, on the stairways between reception and the remainder of the premises and at all other exits including fire exits.
11. Under 18 events may take place to which the following conditions shall apply;
  - i. These events shall finish no later than 23.00 hours, after which there will be a 30 minute period before the nightclub opens to over 18s.
  - ii. The Police and Children's Safeguarding Unit shall be notified in writing or email at least 7 days prior to each event.
  - iii. At least 4 SIA door stewards must be employed throughout the event, which shall include at least 1 female steward.
  - iv. The event shall be promoted to ages 14 years and above.
  - v. There shall be an appropriate number of Youth Workers to provide pastoral care to attendees. Such Youth workers shall have undergone an appropriate CRB check and be registered with the Independent Safeguarding Authority.

**ANNEXES continued ...**

- vi. If alcohol is supplied during one of these events the consumption and sale of alcohol may only take place from the Island Lounge which is a separate area from the main club. No one under the age of 18 shall be allowed access to this area and no drinks shall be allowed to be removed from this area.
  - vii. Only over 18's that have accompanied children to the event shall be allowed entry to the premises.
  - viii. In the main club all alcohol shall be locked and/or obscured from view.
  - ix. All Gaming Machines which prizes and cigarette machines shall be unplugged and locked.
  - x. All promotional material relating to alcohol shall be removed.
  - xi. Any person refusing to be searched shall be refused entry.
  - xii. Throughout children events, the DPS or Personal Licence Holder must be present.
12. The Designated Premises Supervisor must complete the BIIAB National Certificate for Designated Premises Supervisors within 2 months of appointment and produce the appropriate qualification certificate to the Licensing Authority.
13. A record of all staff training and accreditation, including copies of all relevant BIIAB Certificates and records of staff rotas shall be maintained and be made available for inspection by any Responsible Authority upon 7 days request.
14. The premises shall operate a Challenge 25 identification policy and will display appropriate signage at the entrance of the premises to this effect.
15. Staff shall accept as proof of age only the following:-
- i. a valid passport.
  - ii. a photocard driving licence issued in an European Union country.
  - iii. A National ID Card, supported by the Home Office.
  - iv. an official identity card issued by HM Forces or by a European Union country bearing a photograph and date of birth of the bearer.
16. The DPS shall ensure that an Incident Book is kept on the premises and that all incidents are recorded therein on a daily basis. The Incident Book shall be made available for inspection by a police officer, a police licensing officer or members of the local authority section at any reasonable time.
17. A written record of all SIA door stewards shall be kept on the premises and maintained on a daily basis. Such record will include the full name and full SIA licence number of each door steward, the time duty is commenced and completed. At the end of each daily period the Duty Manager or Personal Licence Holder shall sign and date the entries. This record shall be made available for inspection by a police officer, a police licensing officer or members of the local authority licensing section at any reasonable time.
18. Free drinking water shall be available to customers at all times.
19. Suitable signage shall be displayed at the point of entry to the premises and at all points of purchase informing customers re the legal age for the sale of alcohol and the type of identification acceptable.
20. The terraced area shall be well lit at all times.

**Public Safety****1. SANITARY EQUIPMENT AND CLEANLINESS**

- (a) All parts of the Premises, including fittings, shall be kept clean to the satisfaction of the Council.
- (b) Suitable and sufficient sanitary accommodation shall be provided. All lavatories, wash hand basins, water closets and urinals shall at all times be properly maintained in good order and repair, effectively cleansed, ventilated and supplied with water and all necessary requisites. All doors leading thereto shall be suitably marked.

**2. STEWARDS, CAPACITY AND CONTROL**

- (a) Any instructions given by the Council regarding the safety of the audience or any other person present at the entertainment shall be put into effect as soon as required.
- (b) The DPS or Personal Licence Holder shall be in attendance at the Premises throughout the provision of any Licensable Activities and shall be assisted by a staff of attendants or stewards as required by these Standard Conditions and any Special Conditions of the Licence.

**ANNEXES continued ...**

- (c) There shall be a procedure for ensuring that the maximum allowable capacity is not exceeded. Such arrangements shall include provisions whereby any authorised officer of the Council or any member of the Fire and Rescue Service in uniform or a Police Constable can determine, without a physical count, the number of persons on the Premises. Counting by means of a numbered ticket system including complimentary, guest or other free tickets which at any one time for a single performance will indicate the maximum number of persons admitted into the Premises may be substituted in place of counting machines.

**3. ENTRANCES, EXITS, GANGWAYS, FASTENINGS AND NOTICES**

- (a) The exits in the Premises shall be clearly indicated and maintained to afford the public ready and ample means of safe escape.
- (b) In all such premises where it is deemed necessary by the Council and the Fire Service, a diagrammatic plan showing clearly the escape routes and the seating pattern shall be deposited with the Council and a copy displayed within the main entrance to the Premises.
- (c) All exit doors shall be kept unlocked and available for exit during the whole time that the public are on the Premises, provided that any person leaving during a performance or exhibition may be directed to certain exits at the discretion of the management.
- (d) Exit doors shall open in the direction of exit travel. Any doors which have been permitted by the Council to open inwards shall be locked in the open position when the Licence is in force and the public are on the premises. The key shall be removed to a safe place not accessible to members of the public.
- (e) All exit doors must, if fastened during the time the public are on the Premises, be secured during such time by automatic bolts only, of a pattern to be approved by the Council and the Fire Service. Doors secured by such bolts shall be clearly marked "PUSH BAR TO OPEN" in block letters not less than 20 mm. and preferably 50 mm. in height immediately above or below the push bar.
- (f) All doors and fastenings shall at all times be kept in proper working order.
- (g) All exits shall be indicated by the word "EXIT" in plain block lettering not less than 125 mm. high placed above any door or opening leading to any exit. This notice should be placed between 2 m. and 2.5 m. from the floor.
- (h) The word "PRIVATE" or the description of the room to which the door leads shall be painted in letters not less than 25 mm. in height on any door which is in view of the persons present and which does not lead to an exit.
- (i) Exit routes shall be maintained free from obstruction at all times, and in particular, no provision for hanging clothing or storing any article shall be made in corridors, passageways, gangways or exitways.
- (j) All floors, stairs and steps shall be maintained with non-slippery and even surfaces and any floor covering shall be so secured and maintained that it will not ruck or be in any way a source of danger. Mats shall be sunk so as to be flush with the surface of the floor. The nosings and treads of stairs used by the public shall be kept in good repair and shall be conspicuous.
- (k) Persons must not be allowed to stand, sit or otherwise remain in any gangway or exitway.
- (l) Curtains shall not be hung across gangways, exitways or over staircases. Where hung over doorways or across corridors, they shall draw easily from the centre and slide freely and shall be clear of the floor.
- (m) Before the public is admitted to the Premises, the DPS or Personal Licence Holder shall inspect or cause to be inspected all doors, exits and exitways to ensure that the same shall comply with these requirements and that all fastenings and bolts are in proper working order.

**4. SEATING AND STANDING**

**ANNEXES continued ...**

- (a) In any part of the Premises which is regularly or exclusively used for a closely seated audience, all seats shall be securely fixed to the floor.
- (b) In any part of the Premises not so regularly used chairs, if provided, shall be securely fastened together in lengths of not less than four or more than twelve whenever more than 250 persons are to be accommodated. There shall be space of not less than 300mm between the back of one seat and the front of the one behind measured between perpendiculars. Provision shall be made for the end seats in each row which flank the gangways to be securely fastened to the floor.
- (c) Except with the consent of the Council, no seat shall be more than 4 metres from a gangway.
- (d) Where any entertainment involving a closely seated audience is provided, seats must be allocated by row and seat number. The seating arrangements must be notified by the provision of a suitable plan to the Council and the Fire Service. Such seating arrangements shall not be installed or used unless they have been first approved by the Council.

**5. ELECTRICAL, LIGHTING, HEATING AND VENTILATION ARRANGEMENTS**

- (a) The whole of the electrical installation of the Premises shall be installed in a safe and satisfactory manner and shall be maintained in good working order. No work shall be carried out on the system except by a suitably qualified and competent electrician.
- (b) There shall be an inspection of the whole of the electrical installation in the premises at least once in every three year period (or such shorter period as shall have been stipulated in writing by the Council). Such inspection shall be carried out by a competent electrician who shall be required to issue a Certificate of Fitness which must be produced to the Council as required.
- (c) All electrical appliances in the auditorium shall be Portable Appliance Tested and certification shall be available for inspection by the Council upon reasonable notice.
- (d) Any electrical equipment brought into the Premises for a one off event must have been Portable Appliance Tested and such certification shall be made available for inspection by the Council for the duration of the event for which the equipment is in use.
- (e) All wires, cables and conduits from such temporary installations shall be installed in such a way that they shall not be liable to snagging, looping or damage and so become a danger to persons present.
- (f) A record shall be kept of Certificates of Fitness obtained
- (g) The current regulations of the Institution of Electrical Engineers for the electrical equipment shall be taken as a standard for the electrical installation generally.
- (h) A sensitive Earth Leakage Protection System (Residual Current Device) having a rated residual operating current of not exceeding 30 milliamps shall be installed and maintained as part of the fixed power circuit installation. The device shall be regularly tested (at least once a month) and a record of such tests kept in a log book and produced to the Council as required.
- (i) A nominated person conversant with the position of and procedures for dealing with the electrical installation is to be available at all times when the public are on the Premises.
- (j) Where entertainers require a three phase supply, all such equipment shall be installed only by a competent electrical contractor.
- (k) All parts of the premises shall be adequately illuminated and, except where otherwise permitted by the Council, those portions to which the public has access and all routes of escape for performers and staff shall be provided with adequate means of illumination from two independent sources.

## ANNEXES continued ...

- (l) The emergency lighting shall at all times when the public are upon the Premises be maintained in working order and so kept in use (except in such parts as are for the time being adequately lit by daylight) that it is adequate to enable the public to see their way out of the Premises and clear of the building.
- (m) The emergency lighting shall not be controllable from the stage nor from any place accessible to the public.
- (n) The emergency lighting shall be maintained to British Standard 5266, be tested regularly, at least once a month, and a record kept of such tests, such record to be provided to the Council as required.
- (o) In the event of failure of the general lighting, the public shall be required to leave the Premises forthwith.
- (p) In the event of the failure of the emergency lighting, the auditorium shall be immediately fully illuminated by the general lighting and the public shall be required to leave the Premises forthwith.
- (q) Any batteries supplying emergency lighting shall be fully charged before the public are admitted to the Premises. They shall be of such capacity and so maintained as to be capable of supplying at normal voltage the full load of the emergency lighting during the time required for "safe escape" of the public in an emergency.
- (r) When the public has been required to leave the Premises owing to a failure covered by these provisions, they shall not be readmitted until the general lighting or emergency lighting, as the case may be, failure of which was the reason for their being required to leave, shall have been fully restored.
- (s) All lighting to exit notices shall be maintained in good repair and shall not in any circumstances be extinguished or dimmed while the public are on the Premises.
- (t) In all cases where it is desired to install temporary lighting, notice must be given to the Council, in writing, at least 48 hours before the desired commencement of any work.
- (u) All temporary work must be immediately removed when no longer required for the purpose for which it was installed.
- (v) All parts of the premises shall be kept properly and sufficiently ventilated to the satisfaction of the Council and, in those places where it is required for the purposes of the evacuation of smoke, the system shall be installed and maintained to the satisfaction of the Devon Fire and Rescue Service.

**6. FIRE PRECAUTIONS**

- (a) All curtains and drapes within the Premises shall be flame resistant to the satisfaction of the Council. Documentary evidence of the nature and date of any fire-proofing treatment shall be provided to the Council as required.
- (b) The surfaces of walls and ceilings of the Premises to be of not less than Class 1 flame spread as defined by British Standard 476 :Part 7, and escape routes to be not less than Class 0 as defined by paragraph A.8 of Approved Document B2/3/4 of the Building Regulations. No redecoration of these surfaces may be carried out without the prior consent of the Council.
- (c) A competent person trained in the handling and use of the fire equipment provided must be in charge of such equipment during the whole time that the public are on the Premises. The person so in charge shall not be assigned or allowed to perform any duties which will prevent him or her from being immediately available at all times.
- (d) A staff fire drill, including an evacuation procedure, shall be held at least once a month. A record shall be kept of such drills, and made available to the Council as required.
- (e) All possible steps shall be taken to eliminate the danger of fire occurring and all members of staff, stewards and attendants shall be fully instructed in respect of their duties in the event of fire.
- (f) A written copy of fire drill instructions, including action to be taken when a fire or other emergency is discovered, shall be displayed on the premises with these conditions.



ANNEXES continued ...

- (g) No portable heating appliances of any description shall be used in the Premises while the public are present, without the consent of the Council.
- (h) No explosive or highly inflammable material shall be brought into the Premises and no liquefied petroleum gas cylinder shall be used or stored in any part of the Premises whilst the public are present.
- (i) No cotton wool or other similar highly inflammable material shall be used for scenery, decoration or costume.
- (j) Fire fighting equipment and a suitable approved alarm system shall be installed within the Premises and in such a way as shall be required by the Council and the Fire Officer. All such equipment shall be maintained in good and efficient working order and kept ready for use and regularly tested. Portable fire extinguishers should be discharged at regular intervals in accordance with Clause 10:2 of British Standard Code of Practice 5306 : Part 3 : 1980. Any backstage automatic sprinkler installations must be designed, installed and maintained in accordance with the latest requirements of the Fire Officers' Committee by a company entered on that Committee's Approved List of Installers Parts I,II or III. All tests are to be recorded in a log book to be produced as required by the Council.
- (k) Fire appliances containing carbon tetrachloride (CTC) or methyl bromide shall not be kept or used on the Premises.
- (l) Smoking will be prohibited within any stage area and dressing rooms and notices will be prominently displayed to this effect.
- (m) Immediately a fire is discovered or suspected, the Fire Brigade shall be called immediately by dialling 999. Any outbreak of fire, however small, shall be recorded in a log book.
- (n) At least 21 days written notice shall be given to the Council of any proposed dangerous performance or exhibition, including exhibitions involving the use of naked flames and no such exhibition shall be permitted unless prior consent has been given by the Council.
- (o) Combustible materials may only be stored in such positions as may be approved by the Council.
- (p) Heating of the Premises shall be provided and maintained in a manner satisfactory to the Council. If required by the Council, an annual certificate in a prescribed form to the effect that the space heating apparatus and hot water boilers have been examined and tested and are in a safe working condition shall be submitted to the Council upon request.
- (q) Every heating appliance used on the Premises shall be so protected or situated sufficiently far from any woodwork, hangings or other materials that it shall not be likely to catch fire.
- (r) All gas burners must be of a type and position approved by the Council. Gas taps within reach of the public shall be of a secret or safety pattern.

7. **STRUCTURE AND SUITABILITY**

- (a) No alteration, either permanent or temporary, whether in construction or rearrangement of any detail, or otherwise, shall be made in the Premises without the consent of the Council. Plans and particulars, in duplicate, of such alterations must be sent to the Council for approval and no work may commence until such approval is given. Such consent will not be required for any work which is necessary for the efficient maintenance of the approved arrangements and which will be carried out in accordance with these conditions and the Council's technical requirements.
- (b) Notice shall also be given to the Council of any intention to carry out work necessitating the use of internal or external scaffolding, cradles or plant. If the Council shall so require, the Premises shall be closed to the public until the work has been completed and the scaffolding, cradles and plant have been removed.
- (c) In the event of any Premises being closed for the purpose of effecting alterations, additions, repairs, or decorating they shall not be reopened to the public unless and until the consent of the Council shall have been obtained. At least fourteen days notice in writing to the Council shall be given of the intention to reopen the premises and, in order that necessary inspections and tests may be made at the Premises by the Council, a clear interval of 48 hours (not

## ANNEXES continued ...

including Sundays and Bank Holidays) shall elapse between the completion of the building and its equipment in accordance with the requirements of the Council and the date of proposed re-opening of the Premises.

- (d) Except with the prior consent of the Council, no work in connection with any alterations, repairs or redecoration in areas occupied by the public or performers shall be carried out whilst the public are on the Premises.
- (e) Any consent under this Condition does not relieve any necessity to seek a variation in the terms of the Licence where it is clear that such variation would be necessary as the direct result of the works carried out, e.g. Removal of walls between separate rooms so affecting the capacity of each.
- (f) If required by the Council, the Licence Holder shall at his own expense provide a certificate to the effect that the Premises have been examined by a competent Technical Adviser (deemed to be suitable by the Council) and found to be structurally sound for the purpose for which they are intended to be used. Such certificate shall include an inspection of all ceilings and ornamental plasterwork. The certificate shall be renewed every five years or at any other time when required by the Council.
- (g) Where the Licence permits the provision of dancing, a suitable and clearly identifiable single area must be available for this purpose. The minimum area to be set aside shall be four square metres where the Licence permits a maximum capacity of between 1 and 99 people, six square metres where the Licence permits a maximum capacity between 100 and 199 people and nine square metres where the Licence permits a maximum capacity of over 200 people

#### 8. HYPNOTISM AND OTHER ENTERTAINMENTS PROVIDING SPECIAL RISKS

- (a) Unless the express written consent of the Council shall first have been obtained, no entertainment shall be provided in any part of the premises consisting of or involving:-
- Hypnotism (as defined by the Hypnotism Act 1952);
  - The use of special effects, or matters in respect of which special risks will arise, including the introduction to any area occupied by the public of any material, liquid, foam or foodstuff; or
  - The use of any temporary structure or staged area

Applications for such consent must be made in writing in a form to be prescribed by the Council and submitted not less than 28 days (or such other period as the Council may specify in particular circumstances) before the performance is intended to be provided. Additional information considered appropriate to the application may be required to be provided and, after due consideration, additional conditions may be imposed in relation to the entertainment, for which an additional fee may be payable. A copy of the application shall at the same time be forwarded to the Chief Officer of Police and Fire Authority.

- (b) With regard to a performance involving hypnotism, the application shall, in all cases, contain the following particulars. (1) the name and address of the person by whom the exhibition, demonstration or performance is to be given, (hereinafter called "the hypnotist"); (2) a description of the proposed exhibition, demonstration or performance; and (3) a statement as to whether, and if so, giving full details thereof, the hypnotist has been previously refused, or had withdrawn, a consent by any Licensing Authority or been convicted of any offence under the Hypnotism Act 1952 or of an offence involving the breach of a condition regulating or prohibiting the giving of an exhibition, demonstration or performance of hypnotism on any person at a place licensed for public entertainment.

- (c) In relation to any consent given for a hypnotism display, the following conditions shall apply:-

- 1 No exhibition, demonstration or performance shall be held whereby:
- harm is caused or is likely to be caused to any person attending it, any person is caused, while under the influence of hypnotism, to say or do anything offensive to the public; if the Council notifies the DPS in writing that it objects to anything said or done in the course of the exhibition such thing shall not thereafter be included in the exhibition, there is the giving of hypnotherapy or any other form of treatment, there is any experiment in which there is either the age regression of the subject or the subject is suspended between two supports (so called "catalepsy") or there is the giving of suggestions to the subject that he should perform any act or behave in any manner which is likely to be interpreted as indecent, offensive or harmful, nor that the subject should consume any substance which is either noxious or harmful.

## ANNEXES continued ...

- 2 All hypnotic or post-hypnotic suggestions shall be completely removed from the minds of the subjects (including those of the audience) before they leave the room or place in which the performance takes place. Likewise, any post-hypnotic suggestions given shall take place only in the presence of the hypnotist and shall not continue after the performance or away from the room or place in which the performance takes place.
- 3 The exhibition shall conform to the description submitted to the Council unless the Council has required or expressly authorised a modification.
- 4 Any modifications in the exhibition subsequently required by the Council shall be made immediately upon notice thereof being given by the Council to the DPS.
- 5 No inducements shall be offered to any person to subject themselves to the influence of the hypnotist.
- 6 No poster, advertisement or programme relating to the exhibition shall be displayed, sold or supplied by or on behalf of the DPS either at the premises or elsewhere, which is likely to be injurious to morality or otherwise offensive to public feeling; if the Council notifies the DPS in writing that it objects to such an item so displayed, sold or supplied, that item shall not thereafter be displayed, sold or supplied. All such items promoting the exhibition shall draw attention, in a clear and legible manner to the prohibition on the hypnotising of persons under the age of 18 imposed by Section 3 of the Hypnotism Act 1952.

**The Prevention of Public Nuisance**

1. Noise from the premises shall not be audible within any dwelling with windows open for normal ventilation especially after 11pm. This shall be assessed from the boundary to the nearest residential properties, on all sides of the licensed premises. The criteria that shall be applied are;
  - (i) Before 11pm - noise emanating from the premises shall not be clearly distinguishable above other noise.
  - (ii) After 11pm - noise emanating from the premises shall not be distinguishable above background levels of noise.
  - (iii) The local authority shall reserve the right in cases of tonal noise and where premises are attached to others, to make further assessments from within the residential property.
2. A noise limitation device shall be installed to control the system to which all amplification equipment is fitted to ensure that the noise produced within the premises will not be audible within any residential premises in the vicinity. The level of noise shall be set and secured to a level satisfactory to the Environmental Health Department of Torbay Council. The device shall be regularly maintained within maintenance records kept for a minimum of 3 years.
3. Noise shall not be permitted to emanate from the Premises such as to cause persons in the neighbourhood to be unreasonably disturbed. To this end, adequate sound insulation should be provided and regard must be had to the ventilation requirements for the Premises. All sound insulation must be installed to the satisfaction of the Council.
4. The volume of amplified sound used in connection with the entertainment provided shall at all times be under the control of the Management and the controlling mechanism shall be operated from a part of the Premises not accessible to the public.
5. During any period of time where amplified sound is played in any part of the Premises the contents of "The Draft Code of Practice on Sound Levels in Discotheques" (HMSO Ref. ISBN 01175 1862X) be adopted in its entirety on the Premises.
6. Entrances must be provided with lobbies with automatic door-closers. The lobbies are in use throughout the time of entertainment.
7. A senior member of staff (manager) shall assess the impact of any noise activities on neighbouring residential premises at the start of the activity/entertainment and periodically throughout the activity/entertainment to ensure levels of noise have not increased.
8. Staff members shall leave from the front of the premises.
9. Good order and decent behaviour shall be maintained in the Premises during the hours of public entertainment. No performance or exhibition provided shall be of an obscene, indecent or objectionable nature.
10. The Management and Security staff shall at all times use their best endeavours to ensure that persons on or leaving

**ANNEXES continued ...**

the Premises and using adjacent car parks and highways conduct themselves in an orderly manner and do not in any way cause annoyance to residents or persons passing by.

**The Protection of Children from Harm**

1. Suitable signage shall be displayed at all points of sale of alcohol, to remind staff:-
  - a. That alcohol may not be sold to persons aged under 18 and
  - b. What forms of ID may be accepted.

**ANNEXE 3****CONDITIONS ATTACHED AFTER A HEARING BY THE LICENSING AUTHORITY****The Prevention of Crime and Disorder**

1. Whenever the premises attract a queue of people at the front entrance, the queue shall be supervised and contained in a responsible manner and that the obstruction of the footpath and highway, and nuisance to passers-by and local traders is kept to a minimum.
2. Alcohol must not be sold or consumed on the premises during children's parties other than in the Island bar and during such period no alcohol may be removed from the area.

**Public Safety**

1. The use of strobe lighting shall only be permitted in instances where the flicker rate of the output unit is 4 flicks per second or less.
2. In instances where boxing or wrestling matches are provided, written notification must be made to Torbay Council's Health and Safety Team, at least 21 days prior to the event.
3. The use of lasers within the premises shall not be permitted unless the use and installation of the laser system has been approved by Torbay Council's Health and Safety Team. Any changes to the laser system must be made in writing to the Health and Safety Team at least 21 days prior to any changes being made.
4. The stewarding ratio shall be 1:100.

**ANNEXE 4****PLANS**

Copy attached to Licence.

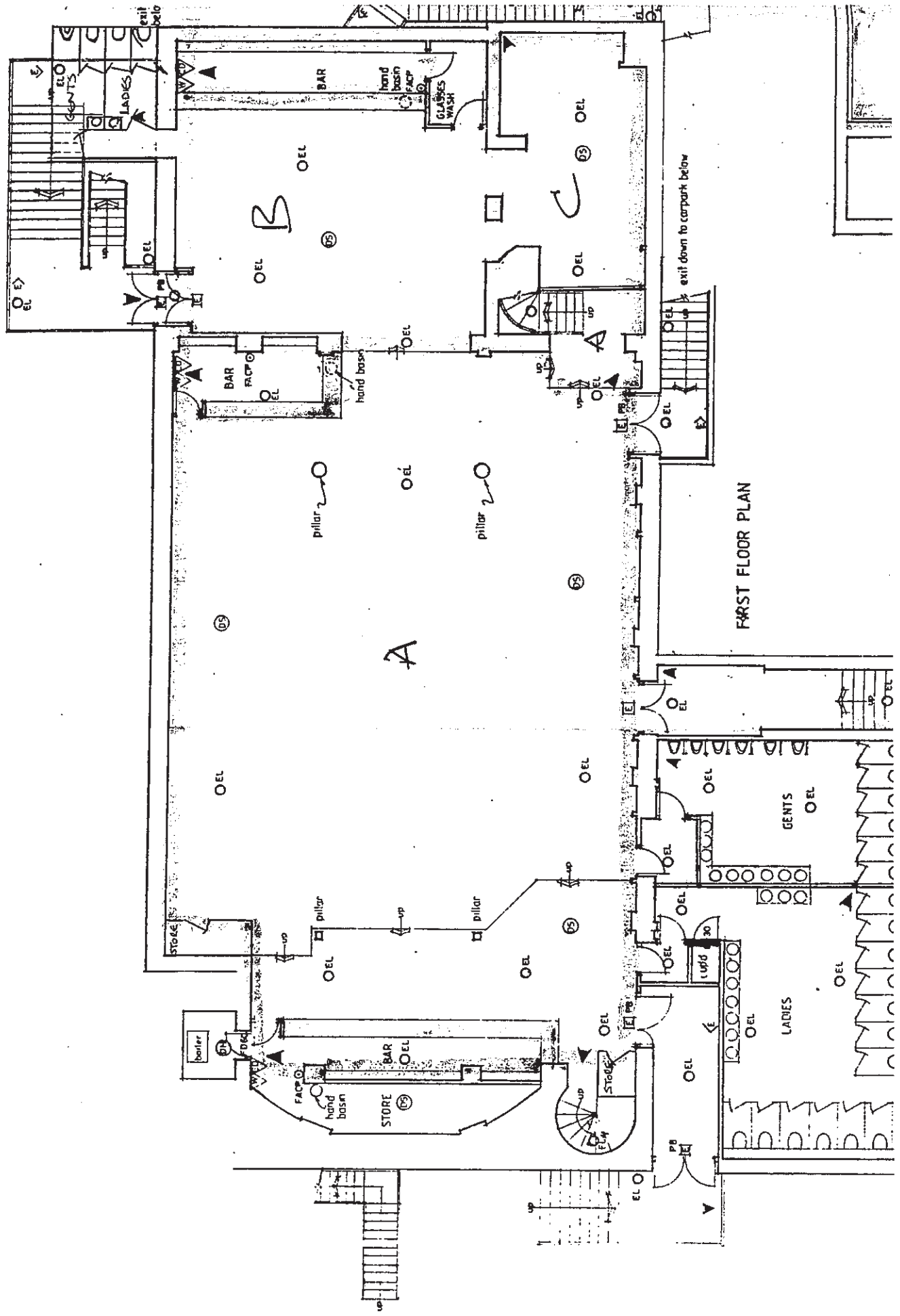

FIRST FLOOR PLAN

- Fire Alarm panel zoned
- Fire Alarm call point
- Smoke detector
- Heat detector
- Emergency light
- Illuminated Exit Sign
- Directional Exit Sign
- Monitor
- Video
- CCTV Camera
- FIRE Blanket
- push bar to open
- push pad to open
- 30min fire door with fire rated over-head door closer to be up graded with intumescent strips & smoke seal
- 60 min fire door as above
- 9 litre Water Fire Extinguisher
- 4.5 KG Carbon Dioxide Extinguisher

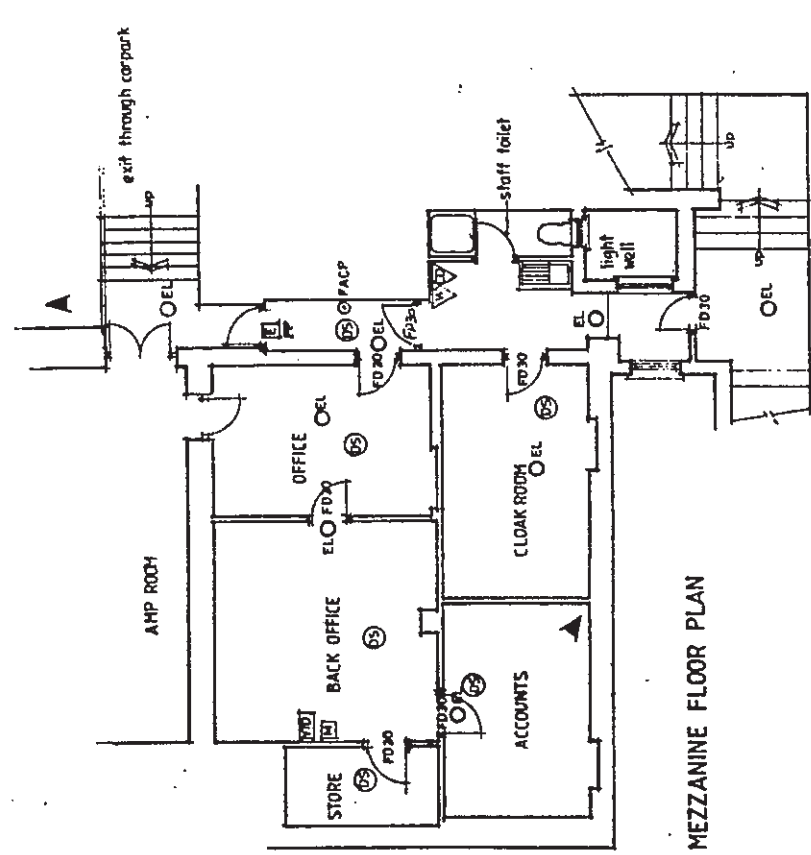

MEZZANINE FLOOR PLAN

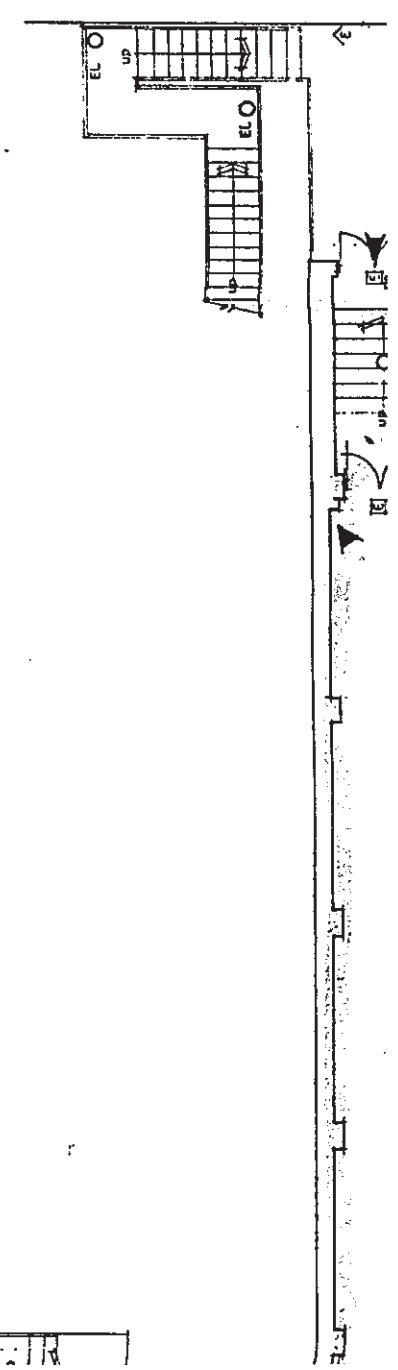

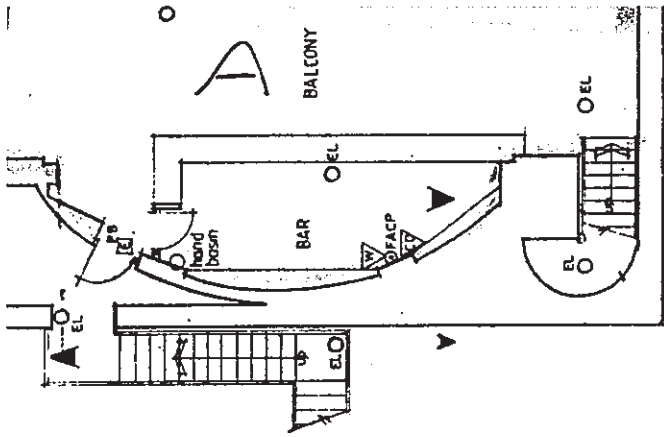
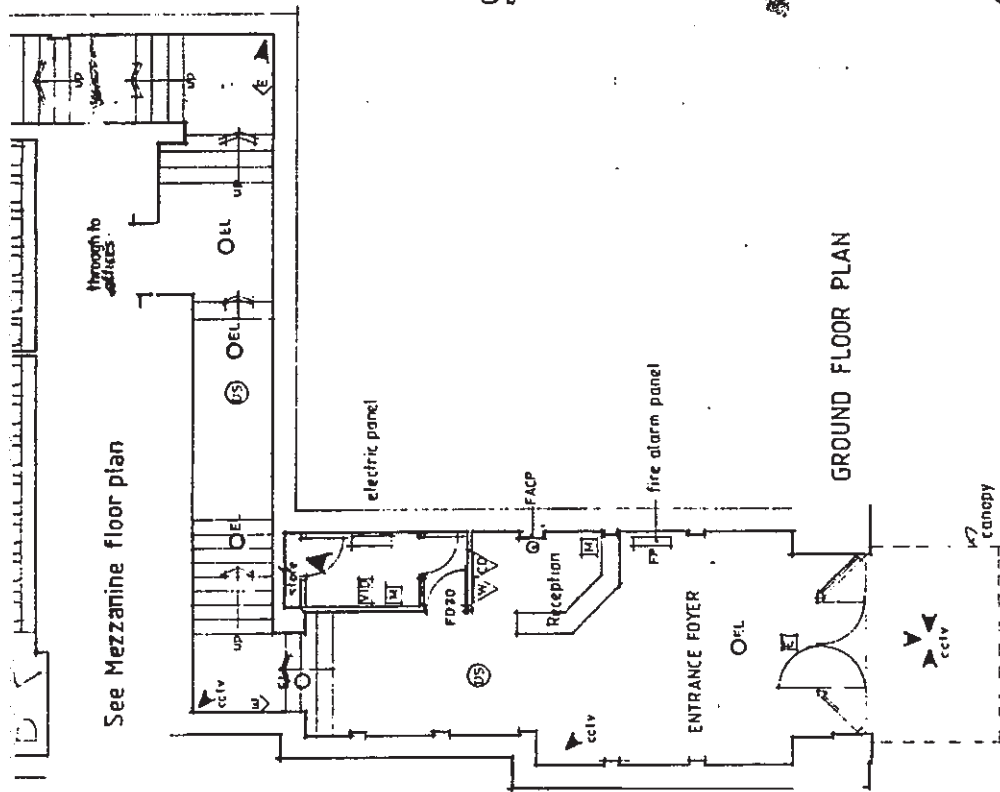

scale 1:100

ALCOHOL

LICENSABLE ACTIVITIES IN OTHER AREAS AS FOLLOWS

- AREA A : ALL
- AREA B : ALCOHOL + BE AND F
- AREA C : ALCOHOL + E AND F
- AREA D : ALL EXCEPT B D J

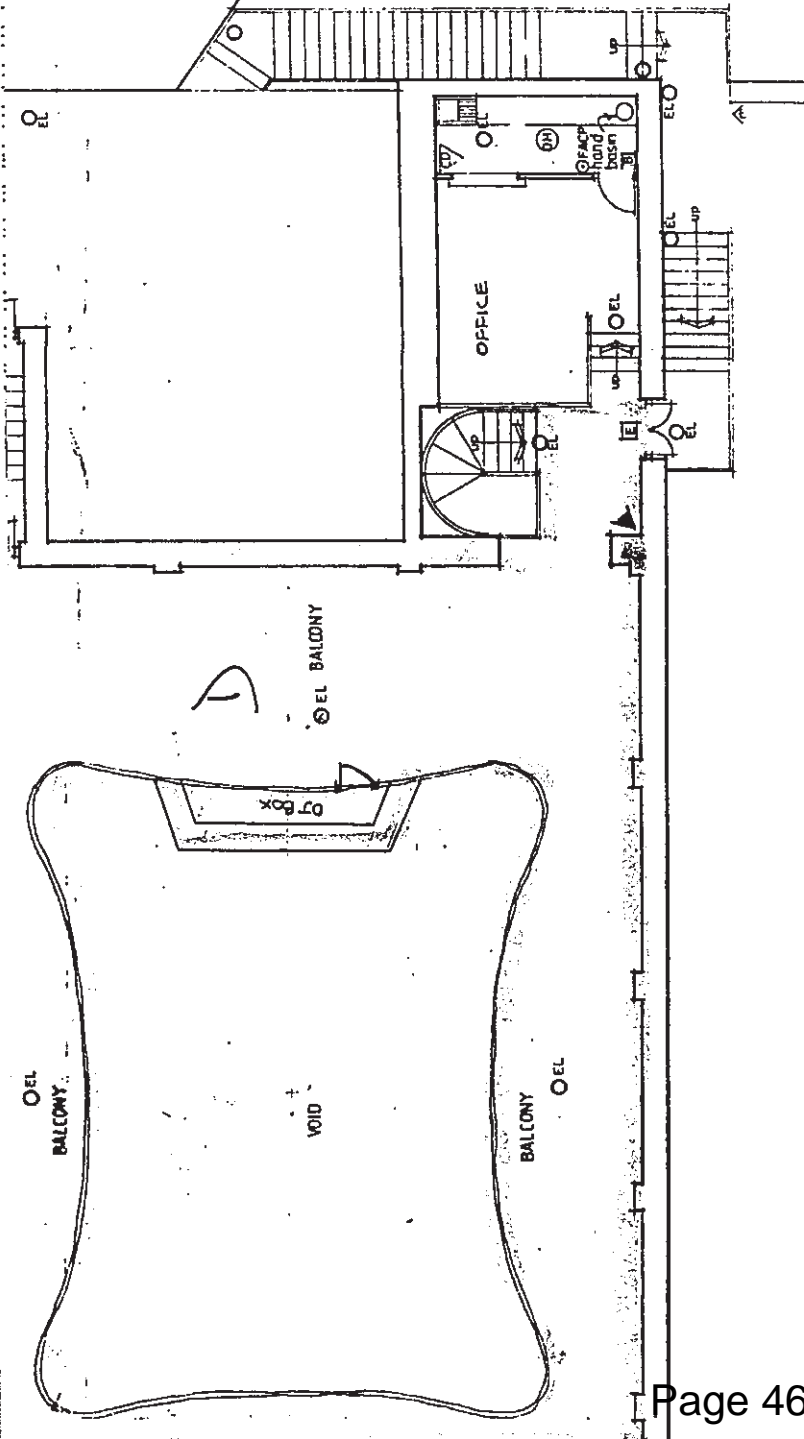

**BURKE ASSOCIATES (No 1 Designs Ltd)**  
 The Lodge  
 10 Weetaborough Drive  
 Marldon  
 Paignton  
 phone 01803 551859

**Project**  
 Proposed Licensing Plan

**Location**  
 ROUTE 66  
 Victoria Parade  
 Torquay

**Client** JJB Developments (UK) Ltd  
**Date** March 2007  
**Scale** 1:100

**Drawing** 711:01



Ref: Harbourside  
Nightclub

TOWN & BAY COUNCIL E.R. & C.P. DIVISION			
24 SEP 2012			
OFFICER	ISSUED BY	FILE NO	DOC No

Dear Sir / Madam

Due to the forthcoming re-opening of the nightclub on the Harbourside (previously 'PURE') we would appreciate consideration to be given regarding noise levels unacceptable by law in a residential area.

We would also like to draw attention to the outdoor smoking area (which has caused various local residents noise problems in the past). An addition of an air-locked door and double doors would possibly prevent a lot of the noise from the club vibrating up to the residential buildings above.

We hope you will give this your kind consideration.

Yours faithfully